



281 C Chiavi a compasso con naselli tondi



DATI TECNICI

- Per ghiera con fori frontali
- Finitura corpo: cromata satinata
- Finitura perni: fosfatata



281 C

Chiavi a compasso con naselli tondi

DISEGNO



TABELLA DISEGNO

Codice	Misura	mm	Ah	B	rD	E	rG	rH	L	O	P	U	Durezza HRC
U02810103	2	10÷40	1.9	3	5.5	8.5	14.0	8.0	160.0	4.0	6.5	6.0	38÷42
U02810104	3	12÷60	2.9	4									
U02810105	4	12÷60	3.9	5									
U02810106	5	12÷60	4.9	5	6	9.5	16.0	10.0	215.0	6.0	6.5	5.5	
U02810107	6	14÷100	5.9	6									
U02810108	7	14÷100	6.9	7	6	9.5	16.0	10.0	215.0	6.0	6.5	5.5	
U02810109	8	14÷100	7.9	8									
U02810110	10	22÷125	9.9	8									
U02810111	12	22÷125	11.9	10									

Dimensioni in mm

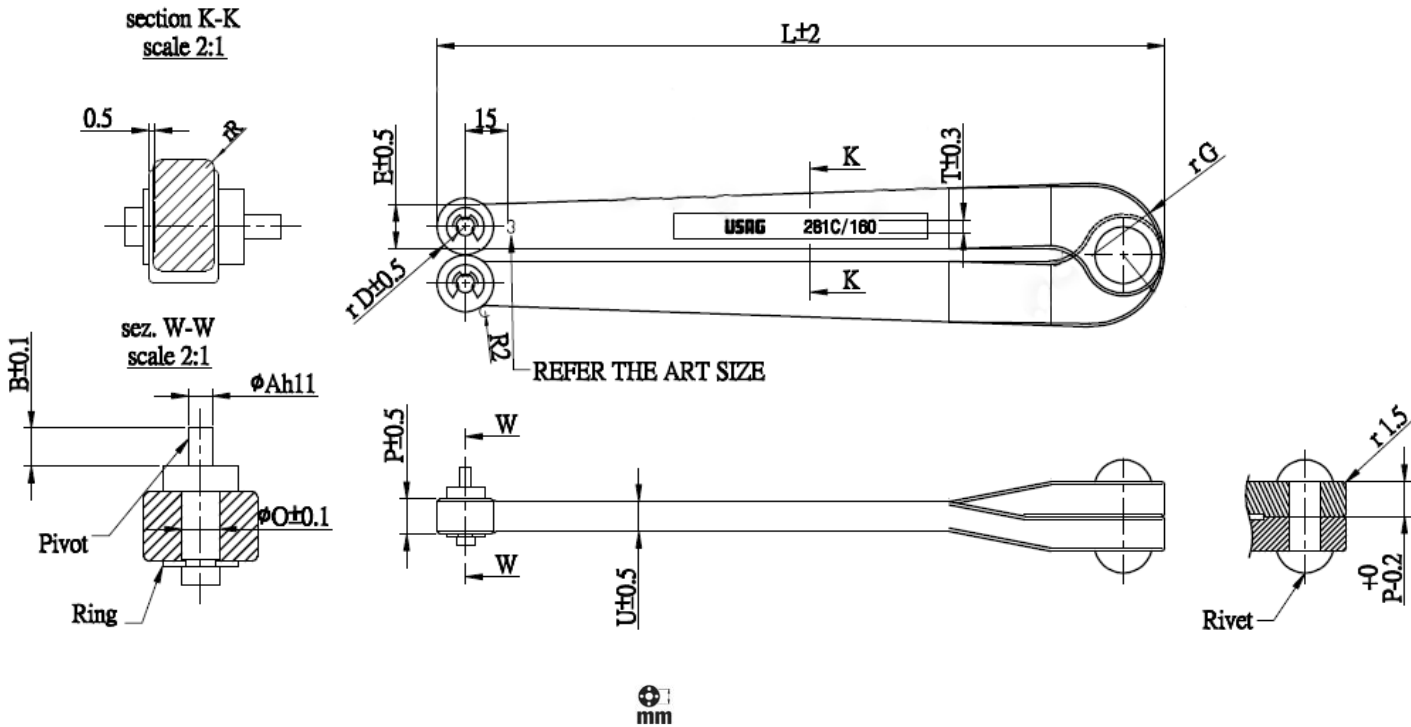

281 C

Chiavi a compasso con naselli tondi

MATERIALI

Acciaio: SCM435L

Finitura corpo: Cromata satinata

Finitura perni: Fosfatata

CONFEZIONAMENTO

- Sacchetto di plastica 2pz
- Misure: 2 – 3 – 4 – 5 – 6 – 7 – 8 – 10 – 12



Stanley Black & Decker Italia Srl
Via Volta, 3 - 21020 Monvalle (VA)
Tel. +39 0332 790111 - Fax +39 0332 790330
info.mv@usag.it

USAG.IT
USAG-TOOLS.NET

UK Importer - USAG UK, 270 Bath Rd, Slough SL1 4DX, England